

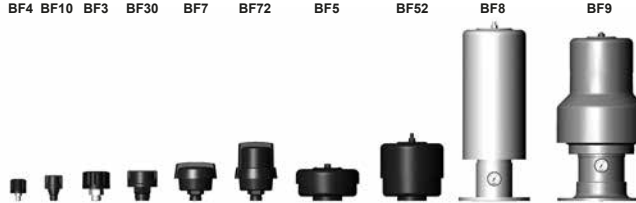

Tank Breather Filter BF up to 11000 l/min



1. TECHNICAL SPECIFICATIONS

1.1 FILTER HOUSING

Construction

Breather filter sizes 4, 10, 3 and 30 consist of a housing which is screwed onto the oil tank, and a built-in filter element.

Sizes 5, 52, 7 and 72 have housings which are screwed onto the oil tank and have one or two exchangeable filter element(s).

BF 5 and 52 are fitted with a built-in oil mist trap as standard.

Sizes 8 and 9 consist of a flange for mounting to the tank, an exchangeable element and a cap. The BF 9 also has an oil mist trap which allows the oil to be drained via an oil drain plug.

1.2 FILTER ELEMENTS

HYDAC filter elements are validated and their quality is constantly monitored according to the following standards:

- ISO 2941
- ISO 2942
- ISO 2943
- ISO 3724
- ISO 3968
- ISO 11170
- ISO 16889

Contamination retention capacities in g

| | Paper |
|----|-------|
| BF | 3 µm |
| 4 | 2.9 |
| 10 | 2.9 |
| 3 | 6.2 |
| 30 | 6.2 |
| 7 | 26.1 |
| 72 | 52.2 |
| 5 | 85.1 |
| 52 | 170.2 |

The filter elements are made from phenolic resin impregnated paper and cannot therefore be cleaned.

1.3 FILTER SPECIFICATIONS

| | |
|--|---|
| Temperature range | -30 °C to +100 °C |
| Material of housing | Steel, zinc-plated/plastic coated (BF 4, 3), Steel (BF 5, 52) Steel, galvanized (BF 8) Aluminium (BF 9) Glass fibre reinforced plastic (BF 10, 30, 7, 72) |
| Type of clogging indicator | VMF (pressure gauge) |
| Pressure setting of clogging indicator | 0.6 bar K pressure gauge 0.035 bar UBM indicator (others on request) |

1.4 SEALS

NBR (= Perbunan) on filter
Polyurethane on element
Cardboard on mounting flange

1.5 SPECIAL MODELS AND ACCESSORIES

- with check/bypass valve to support the suction characteristics of the pump
Not 100% air-tight or leakage-free!
(only BF 10 (except for G¹/₄), 3, 30, 5 and 52)
- with anti-splash device
(only BF 10, 3, 30, 7, 72)
- with connection for a clogging indicator
(only BF 7, 72, 8, 9)
- with manual pressure release
(= BFPR; only BF 10)

1.6 SPARE PARTS

See Original Spare Parts List

1.7 CERTIFICATES, APPROVALS, STANDARDS

BF 7, 72 to Renault standard;
others on request

1.8 COMPATIBILITY WITH HYDRAULIC FLUIDS ISO 2943

The standard models are suitable for use with mineral and lubrication oils. For fire-resistant and biodegradable oils, see tables:

| BF | HFA | HFC | HFD-R |
|---------------|-----|-----|-------|
| 4, 3, 5, 52 | - | - | - |
| 10, 30, 7, 72 | ● | ● | - |
| 8, 9 | ● | ● | ● |

- HFA oil in water emulsion (H₂O content ≥ 80 %)
- HFC water polyglycol solution (H₂O content 35-55 %)
- HFD-R synthetic, water-free phosphate ester

Biodegradable fluids

| BF | HTG | HE | HPG | PRG |
|---------------|-----|----|-----|-----|
| 4, 10, 3, 30, | + | + | ● | ● |
| 7, 72, 5, 52 | + | + | ● | ● |
| 8, 9 | + | + | ● | ● |

+ suitable for all

● contact our Technical Sales Department

- not suitable

- HTG vegetable oil based hydraulic fluids
- HE ester-based synthetic hydraulic fluids
- HPG polyglycol-based synthetic hydraulic fluids
- PAG sub-group of HPG: polyalkylene glycol
- PEG sub-group of HPG: polyethylene glycol

1.9 CHANGING INTERVALS

The filter elements or filters must be replaced as frequently as the fluid filters, but at least every 12 months.

Symbol

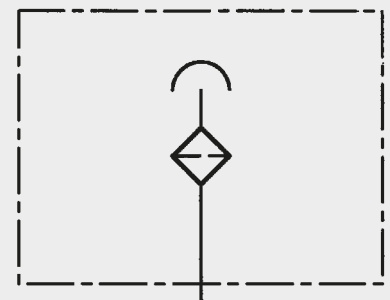

2. MODEL CODE (also order example)

2.1 COMPLETE FILTER

2.1.1 BF 4 and 3

Filter type BF
Filter material P Paper
Size of filter BF 4, 3
Type and size of connection

| Des. | Type | Connection | Filter size | |
|------|-------------------|------------|-------------|-----|
| | | | BF4 | BF3 |
| G | Thread ISO 228 | G 1/4 | • | |
| | | G 1/2 | | • |
| | | G 3/4 | | • |
| | | G 3/8 | | • |

Filtration rating in µm

P 3 (absolute)

Type of clogging indicator

W without port, no clogging indicator

Type code

| Size | Code | Connection | Δp [bar] |
|------------|------|------------|----------|
| BF 3 | 1.X | G 3/4 | - |
| BF 3 | 2.X | G 3/8 | - |
| BF 3 | 3.X | G 1/2 | - |
| BF 3../-RV | 4.X | G 3/4 | 0.4 |
| BF 3../-RV | 5.X | G 3/4 | 0.7 |
| BF 3../-RV | 6.X | G 3/4 | 0.2 |
| BF 3../-RV | 7.X | G 3/4 | 1.0 |
| BF 4 | 1.X | G 1/4 | - |

Modification number

X the latest version is always supplied

Supplementary details

RV check/bypass valve (not for BF 4)

2.1.3 BF 7 and 72

Filter type BF
Filter material P Paper
Size BF 7, 72
Type and size of connection

| Des. | Type | Connection | Filter size | |
|------|-------------------|---------------|-------------|----|
| | | | 7 | 72 |
| G | Thread ISO 228 | G 1 | • | • |
| | | | | |
| N | NPT-Thread | 3/4 | • | • |
| U | UNF-Thread | G 1 5/16-12UN | • | • |
| M | metric connection | M30 x 1.5 | • | • |

Filtration rating in µm

P 3 (absolute)

Type of clogging indicator

W without port, no clogging indicator

K pressure gauge (measuring range -1 to +0.6 bar) (not for BF 72)

UBM visual/analogue vacuum gauge with manual reset (pressure setting: -0.035 bar)

Type code

1

Modification number

X the latest version is always supplied

Supplementary details

AS anti-splash device (not for model with K pressure gauge)

2.1.2 BF 10 and 30

Filter type BF
Filter material P Paper
Size of filter BF 10, 30
Type and size of connection

| Des. | Type | Connection | Filter size | |
|------|-------------------|----------------|-------------|------|
| | | | BF10 | BF30 |
| G | thread ISO 228 | G 1/4 | • | |
| | | G 3/8 | • | |
| | | G 3/4 | | • |
| M | metr. connection | M 42x2 | | • |
| | | M 30x1.5 | | • |
| | | M 22x1.5 | • | |
| N | NPT thread | 1/2 | • | |
| U | UNF thread | 3/4 | | • |
| | | 1 1/16-12UN-2A | • | • |

Filtration rating in µm

P 3 (absolute)

Type of clogging indicator

W without port, no clogging indicator

Type code

| Size | Code | Connection |
|------------|------|----------------|
| BF 30 G... | 1.X | G 3/4 |
| BF 30 M... | 1.X | M 42x2 |
| BF 30 M... | 2.X | M 30x1.5 |
| BF 30 N... | 1.X | NPT 3/4 |
| BF 30 U... | 1.X | 1 1/16-12UN-2A |
| BF 10 G... | 1.X | G 1/4 |
| BF 10 G... | 2.X | G 3/8 |
| BF 10 M... | 1.X | M 22x1.5 |
| BF 10 N... | 1.X | NPT 1/2 |
| BF 10 U... | 3.X | 1 1/16-12UN-2A |

Modification number

X the latest version is always supplied

Supplementary details

AS anti-splash without check/bypass valve

RV0.2 valve with relevant pressure setting
 RV0.4 (not for BF 10 with G 1/4)
 RV0.7

2.1.4 BF 5 and 52

Filter type BF
Filter material P Paper
 BN Betamicon®
Size of filter BF 5, 52
Type and size of connection

| Des. | Type | Conn. | Filter size | |
|------|-------------------|---------|-------------|----|
| | | | 5 | 52 |
| G | Thread ISO 228 | G 2 1/2 | • | • |
| | | | | |
| N | NPT-Thread | 2 1/2 | • | • |

Filtration rating in µm

BN 3, 10 (absolute)

P 3 (absolute)

Type of clogging indicator

W without port, no clogging indicator

Type code

1

Modification number

X the latest version is always supplied

Supplementary details

RV0.4 check/bypass valve with 0.4 bar pressure setting
 SO479 filter suitable for HFC fluids

2.1.5 BF 8 and 9

Filter type _____ **BF BN 8 F 1 A 1 . X**

BF

Filter material _____

BN Betamicron®

BN/AM Betamicron®/Aquamicron®

Size of filter _____

BF 8, 9

Type and size of connection _____

| Des. | Type | Filter size | |
|------|--------|-------------|---|
| | | 8 | 9 |
| F | Flange | • | • |

Filtration rating in µm _____

BN 1, 2 for BF 8

BN 2 for BF 9

BN/AM 1 for BF 8

Type of clogging indicator _____

A blanking plug in indicator port

K pressure gauge (measuring range -1 to +0.6 bar)

Type code _____

1

Modification number _____

X the latest version is always supplied

2.2 REPLACEMENT ELEMENT

Size _____ **0005 L 003 P**

0005 for BF 5, 52 (on BF 52: 2 x 0005 L...)

0007 for BF 7

0072 for BF 72

0008 for BF 8

0009 for BF 9

Type _____

L

Filtration rating in µm _____

P: 003 (BF 5, 52, 7, 72)

BN: 001, 002 (BF 8)

BN: 002 (BF 9)

BN: 003, 010 (BF 5, 52)

BN4AM:001 (BF 8)

Filter material _____

P Paper (BF 5, 52, 7, 72)

BN Betamicron® (BF 5, 52, 8, 9)

BN4AM Betamicron®/Aquamicron® (BF 8)

Replacement elements cannot be ordered for BF 4, 10, 3, 30.

These filters are only available complete!

2.3 REPLACEMENT CLOGGING INDICATOR

Type _____ **VMF 0.6 K . X**

VMF Return line indicator

Pressure setting _____

0.6 -1 to +0.6 bar

0.035 -0.035 bar

Type _____

A blanking plug in indicator port

K pressure gauge (pressure setting -1 to +0.6 bar)

UBM visual-analogue vacuum gauge with manual reset (pressure setting: -0.035 bar)

Modification number _____

X the latest version is always supplied

2.4 MODEL CODE FOR BF 7 AND 72 TO RENAULT SPECIFICATION

BF P 7 F 3 UBM 0 . X

Size _____
 7 Tank volume from 20 to 400 litres
 72 Tank volume over 400 litres

Type and size of connection _____

| Des. | Type | Filter size | |
|------|-----------------------|-------------|----|
| | | 7 | 72 |
| G | with threaded adapter | • | • |
| F | with flange adapter | • | • |
| S | with weld adapter | • | • |

Type of clogging indicator _____

UBM visual analogue vacuum pressure gauge with manual reset, measuring range 0 to +0.035 bar

Type code (TKZ) _____

- 0 without adapter (basic model)
- 2 incl. adapter with male thread G $\frac{3}{4}$
- 3 incl. adapter with female thread 1 $\frac{1}{2}$ -16 UNC
- 4 incl. adapter with female thread G $\frac{3}{4}$
- 5 incl. flange adapter (1 $\frac{1}{2}$ -16 UNC)
- 6 incl. flange adapter (G $\frac{3}{4}$)
- 7 incl. weld adapter (1 $\frac{1}{2}$ -16 UNC)
- 8 incl. weld adapter (G $\frac{3}{4}$)
- 9 incl. adapter with male thread G 1 $\frac{1}{4}$

Modification number _____

- X the latest version is always supplied
- EFS Filling protection

Basic model

With threaded adapter

With flange adapter

With weld adapter

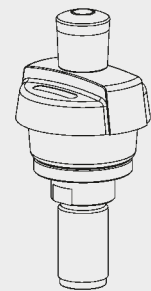
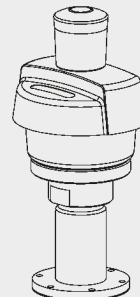
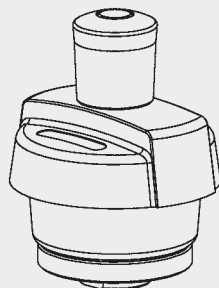
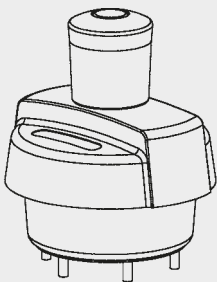

Dimensions BF 7/72 to RENAULT specification

Interface to
DIN 24557/Pt 2

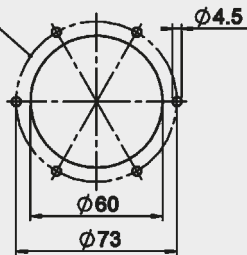

BF 7

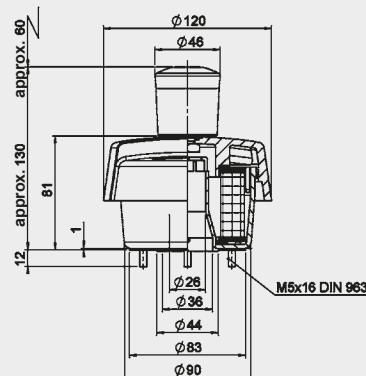

BF 72

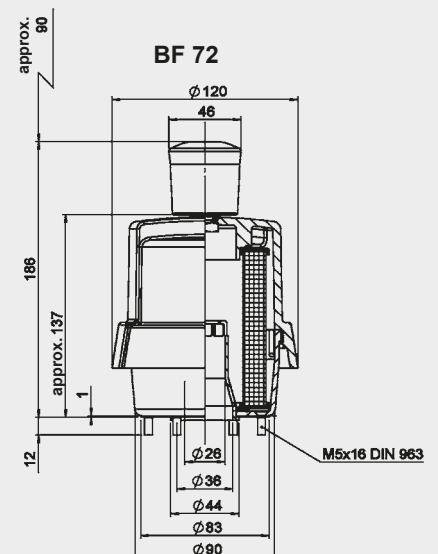

For further information on the BF7/72 to Renault specification please contact HYDAC.

2.5 BREATHER FILTER WITH MANUAL PRESSURE RELIEF BFPR

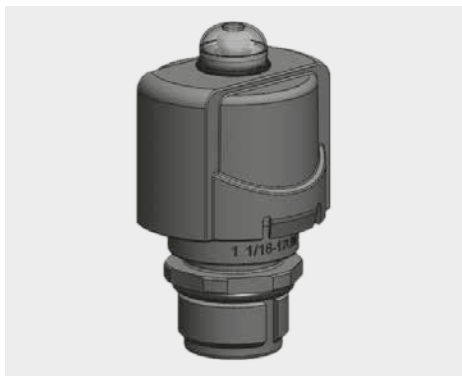

TECHNICAL DESCRIPTION

Breather filters with manual pressure release "BFPR" consist of a housing which is screwed onto the oil tank and which has an integrated air filter element.

An integrated valve allows the oil tank to be pressurized to different pressures, for example to support the pump during start-up, thereby avoiding cavitation of the pump.

The manual pressure release function enables complete pressure release which is initiated when the pressure release button is pressed. This pressure release is required for example before carrying out maintenance on the tank and connecting pipes or hoses, to prevent potential accidents or injury by opening a pressurized system.

CAUTION:

This filter must not be used as a safety valve!

Max. flow rate: 200 l/min
Weight: 0.22 kg

Curves and further information on request.

MODEL CODE

| Type | Filter material | Size | Type of connection | Filtration rating (µm) | Type of clogging indicator | Type code | Modification number | Supplementary details |
|------|--------------------------------------|------|---|------------------------|--|-----------|--|---|
| BFPR | P = phenolic resin impregnated paper | 10 | U = 1 1/16-12UN-2A others on request | 3 | W = without port (no clogging indicator) | 1 | .x = The latest version is always supplied | RV0.35 = pre-charge pressure 0.35 bar RV0.7 = pre-charge pressure 0.7 bar RV1.15 = pre-charge pressure 1.15 bar Required information! |

DIMENSIONS

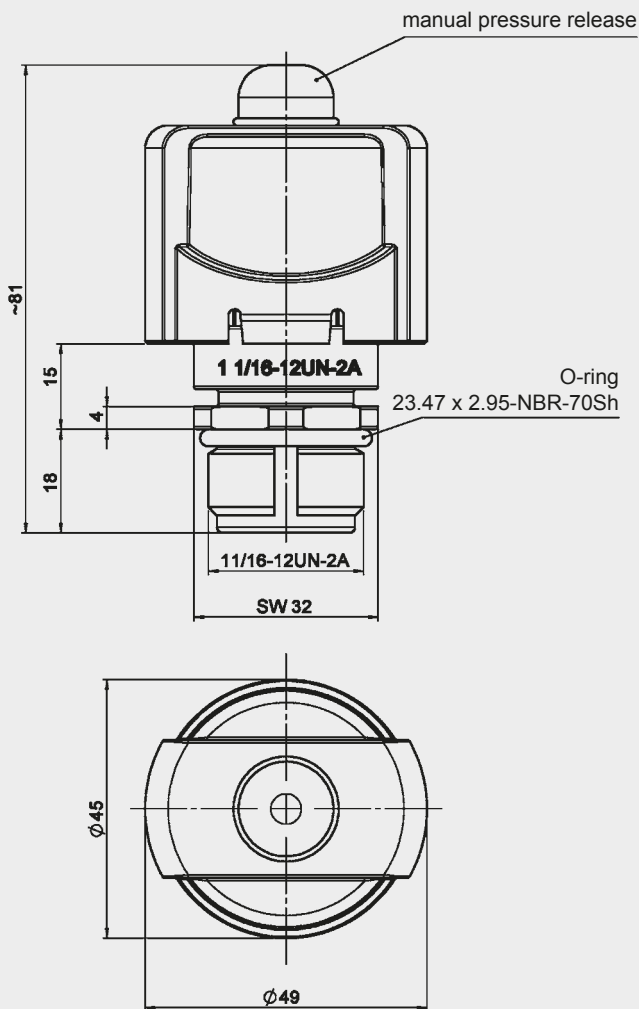

2.6 BREATHER FILTER BF 6 – INTEGRATED CHECK VALVE OPTION AVAILABLE



TECHNICAL DESCRIPTION

The latest breather filter development from HYDAC is the BF 6.

The BF 6 can be fitted with a hydrophobic filter element ("DRY") with an ~ 1,500 cm² filter surface, thus removing any water spray.

Option available with four integrated check valves to enable tank pre-charging – even at different pressure settings.

- Max. flow rate: 500 l/min
- Material: plastic (PA 6)
- Sealing material: NBR; HNBR
- Filter material: hydrophobic material (DRY) or material impregnated with phenol resin (P)
- Connections: G 3/4 (inner)
- Weight: 0.3 kg

Please contact us for further information and characteristics!

MODEL CODE

| Type | Filter material | Size | Type of connection | Filtration rating (µm) | Type of clogging indicator | Type code | Modification number | Supplementary details |
|------|--|------|---|------------------------|--|-----------|--|-------------------------------------|
| BF | DRY = Hydrophobic material P = Material impregnated with phenol resin | 6 | G = Thread G 3/4 More available on request | 5 | W = No clogging indicator option K = Pressure gauge (pressure setting -1 to +0.6 bar) | 1 | .x = The latest version is always supplied | RV0.3 = Pre-charge pressure 0.3 bar |

DIMENSIONS

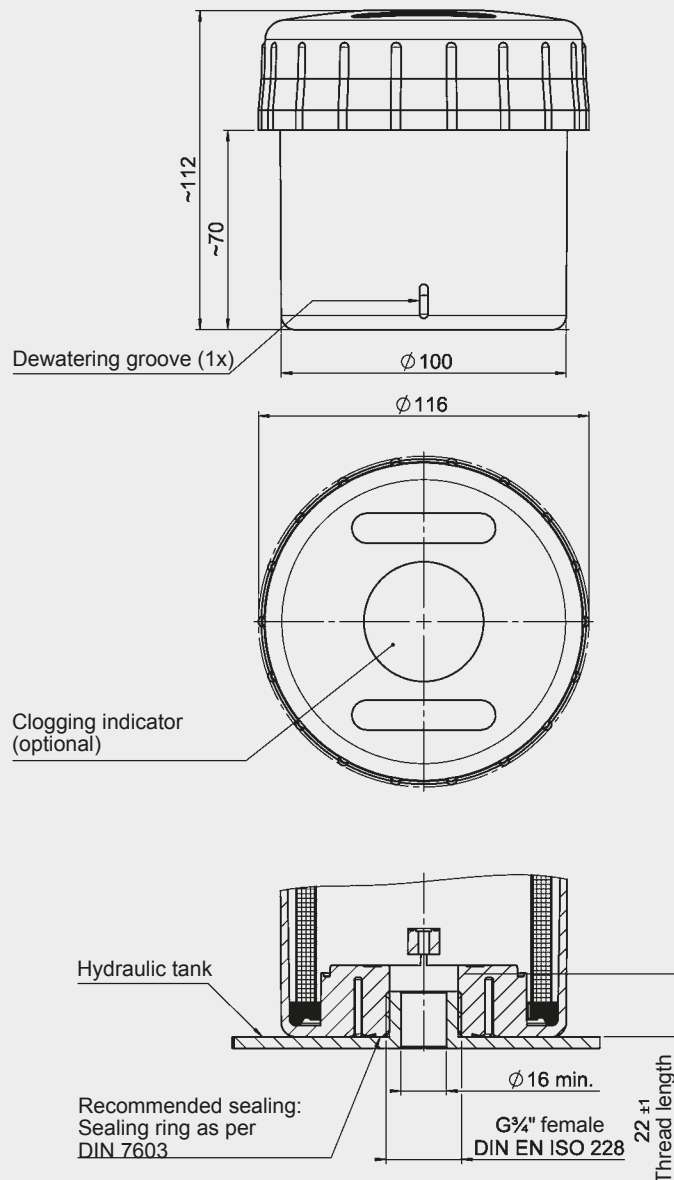

3. FILTER CALCULATION / SIZING

3.1 SINGLE PASS FILTRATION PERFORMANCE DATA FOR AIR FILTER ELEMENTS

The following separation values were established under real-life simulated conditions.

This means that the selected velocity of the flow against the filter mesh-pack was 20 cm/s and the contamination added was 40 mg/m³ of ISO MTD test dust.

| Filtration rating | Retention value d... | For particle size | Filter material |
|-------------------|----------------------|-------------------|-----------------|
| 3 µm | d 80 | 0.74 µm | Paper |
| | d 100 | 2.64 µm | |
| 10 µm | d 80 | 0.25 µm | BN |
| | d 100 | 0.84 µm | |

The d 80 value refers to the particle size which is filtered out at a rate of 80 % during the retention test.

The particle size determined by this method is called the nominal filtration rating of the air filter. The d 100 value therefore refers to the particle size which is filtered out at a rate of 100 % during the single pass test.

The particle size determined by this method is called the absolute filtration rating of the air filter.

Table of average dust concentrations in real life:

| | |
|--|------------------------------|
| Urban regions with a low level of industry | 3-7 mg/m ³ air |
| General mechanical engineering | 9-23 mg/m ³ air |
| Construction industry (wheeled vehicles) | 8-35 mg/m ³ air |
| Construction industry (tracked vehicles) | 35-100 mg/m ³ air |
| Heavy industry | 50-70 mg/m ³ air |

3.2 DIFFERENTIAL PRESSURE ACROSS BREATHER FILTER

The differential pressure (with clean element) for the various filter sizes is shown in the graphs under Point 3.4.

3.3 SIZING GUIDELINES

The rate at which contamination enters a hydraulic system can be considerably reduced by using efficient tank breather filtration.

Caution:

Incorrectly sized tank breather filters can place additional strain on the system and reduce the service life of hydraulic filter elements.

For optimum sizing the following should therefore be observed:

- Filtration rating of breather filter ≤ filtration rating of hydraulic filter
- Only use breather filters with an absolute retention rate ($d_{100} \leq x \mu\text{m}$; x = given filtration rating)
- Max. permitted initial pressure loss: 0.05 bar, optionally 0.01 bar (with a clean filter element and calculated air flow rate)
- Determining the calculated air flow:
 $Q_A = f5 \times Q_p$
 Q_A = calculated air flow in l_N/min
 $f5$ = factor for operating conditions
 Q_p = max. flow rate of the hydraulic pump in l/min

| Ambient conditions | Factor f5 |
|---|-----------|
| Low dust concentration; filter fitted with clogging indicator; continuous monitoring of the filter | 1-2 |
| Average dust concentration; filter without clogging indicator; intermittent monitoring of the filter | 3-6 |
| High dust concentration; filter without clogging indicator; infrequent or no monitoring of the filter | 7-10 |

3.4 AIR FLOW RATE

BF 4

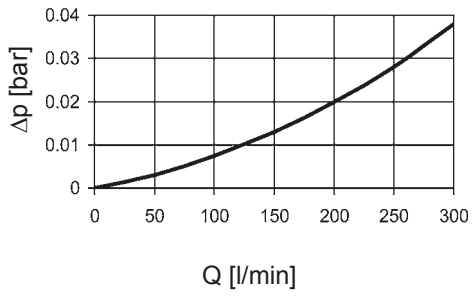

BF 10

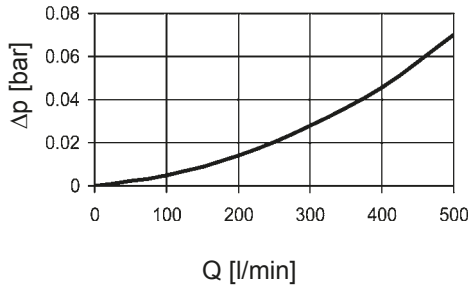

BF 3

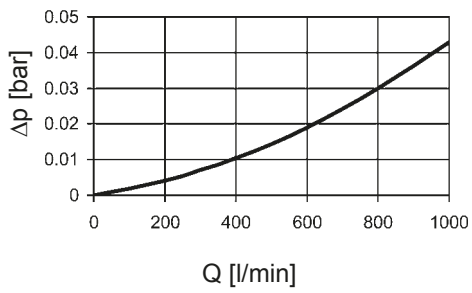

BF 30

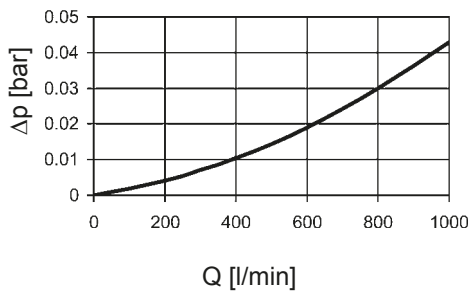

BF 7

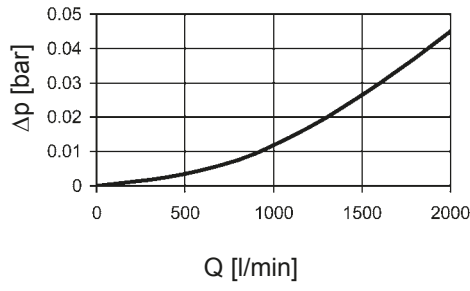

BF 72

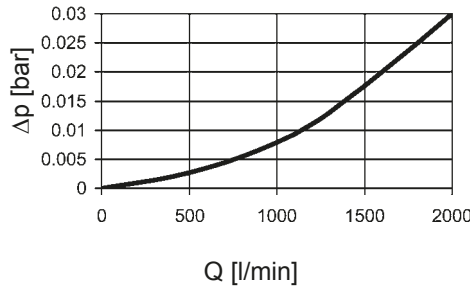

BF 5

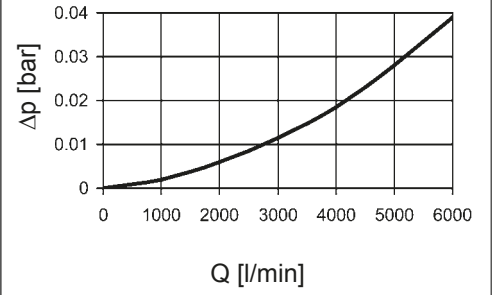

BF 52

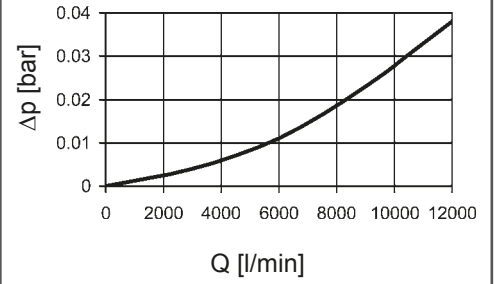

BF 8

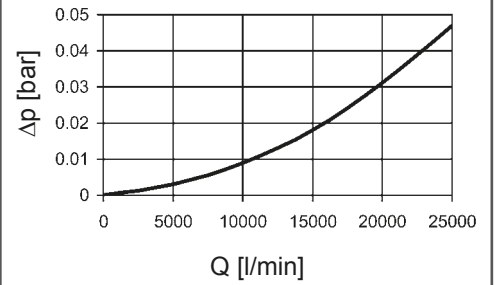

BF 9

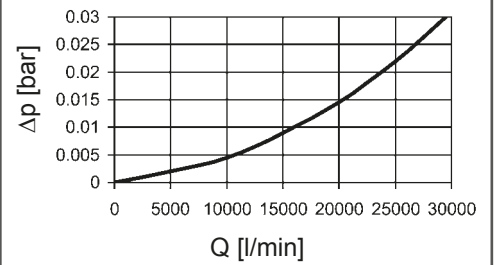

Pressure drop curves for BF filters with check/bypass valve (version /-RV...) on request.

4. DIMENSIONS

Tank requirements

1. In the filter contact area, the tank flange should have a maximum flatness of 0.3 mm and RA 3.2 µm maximum roughness.
2. In addition, the contact area should be free of damage and scratches.
3. The fixing holes of the tank flange must be blind, or stud bolts with threadlocker must be used to fix the filter.
As an alternative, the tank flange can be continuously welded from the inside.
4. Both the tank sheet metal and/or the filter mounting flange must be sufficiently robust so that neither deform when the seal is compressed during tightening.

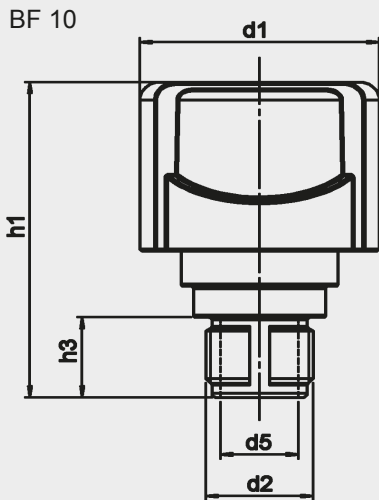
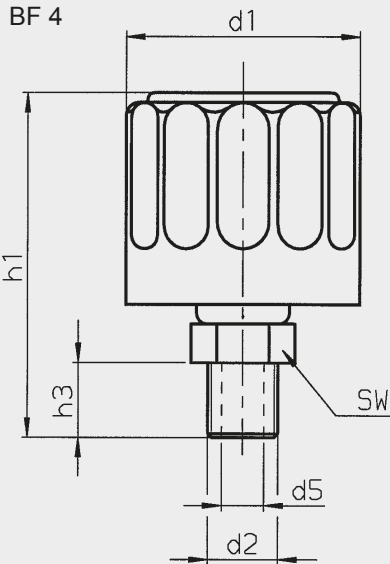

| Type | BF 4... |
|--------|---------|
| d1 | 44 |
| d2 | G ¼ |
| d5 | 8 |
| h1 | 62 |
| h3 | 13.5 |
| SW | 17 |
| Weight | 0.08 kg |

| Type | BF 10 "G"... | BF 10 "M"... |
|--------|--------------|--------------|
| d1 | 49 | 49 |
| d2 | G ¼ | M22x1.5 |
| d5 | 7 | 16 |
| h1 | 64 | 71 |
| h3 | 13.5 | 18 |
| Weight | 0.047 kg | 0.052 kg |

| Type | BF 10 "U"... | BF 10 "N"... |
|--------|--------------|--------------|
| d1 | 49 | 49 |
| d2 | 1 1/16-12 UN | NPT ½ |
| d5 | 16 | 14 |
| h1 | 71 | 71 |
| h3 | 18 | 18 |
| Weight | 0.059 kg | 0.049 kg |

BF 3

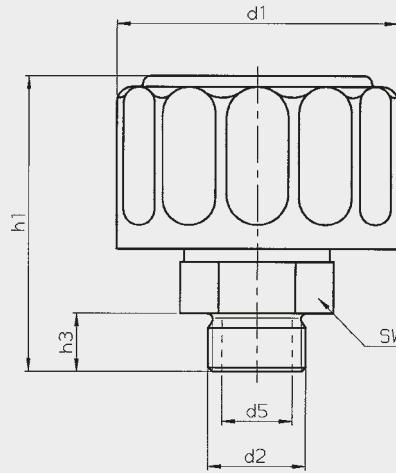

BF 30

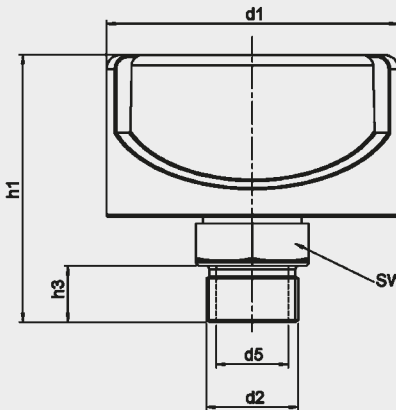

| Type | BF 3...1.X | BF 3...2.X | BF 3...3.X |
|--------|------------|------------|------------|
| d1 | 76 | 76 | 76 |
| d2 | G ¾ | G 3/8 | G ½ |
| d5 | 19 | 12 | 15 |
| h1 | 79 | 72 | 76 |
| h3 | 16 | 12 | 14 |
| SW | 36 | 22 | 27 |
| Weight | 0.33 kg | | |

| Type | BF 30 "G"...1.X | BF 30 "M"...1.X | BF 30 "M"...2.X |
|--------|-----------------|-----------------|-----------------|
| d1 | 83 | 83 | 83 |
| d2 | G ¾ | M42x2 | M30x1.5 |
| d5 | 20.5 | 34.5 | 20.5 |
| h1 | 76 | 76 | 76 |
| h3 | 16 | 16 | 16 |
| SW | 32 | 46 | 32 |
| Weight | 0.12 kg | 0.13 kg | 0.12 kg |

| Type | BF 30 "N"...1.X | BF 30 "U"...1.X |
|--------|-----------------|-----------------|
| d1 | 83 | 83 |
| d2 | NPT ¾ | 1 1/16-12 UN |
| d5 | 20.5 | 20.5 |
| h1 | 76 | 76 |
| h3 | 16 | 16 |
| SW | 32 | 32 |
| Weight | 0.12 kg | |

BF 7

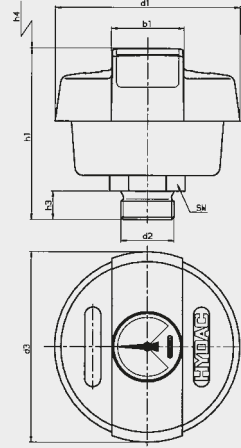

BF 72

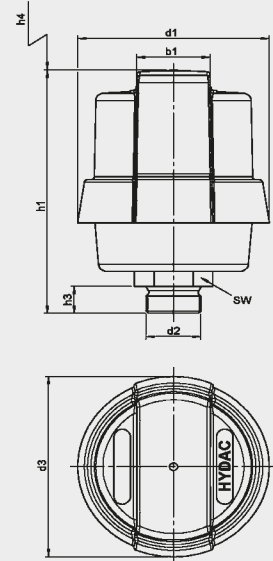

| Type | BF 7 "G" | BF 72 "G" |
|--------|----------|-----------|
| d1 | 116 | 116 |
| d2 | G 1 | G 1 |
| d3 | 120 | 120 |
| h1 | 110 | 162 |
| h3 | 18 | 18 |
| h4 | 60 | 90 |
| b1 | 44 | 44 |
| SW | 41 | 41 |
| Weight | 0.40 kg | 0.65 kg |

| Type | BF 7 "N" | BF 72 "N" |
|--------|----------|-----------|
| d1 | 116 | 116 |
| d2 | NPT ¾ | NPT ¾ |
| d3 | 120 | 120 |
| h1 | 110 | 162 |
| h3 | 18 | 18 |
| h4 | 60 | 90 |
| b1 | 44 | 44 |
| SW | 32 | 32 |
| Weight | 0.40 kg | 0.65 kg |

| Type | BF 7 "U" | BF 72 "U" |
|--------|--------------|--------------|
| d1 | 116 | 116 |
| d2 | 1 5/16-12 UN | 1 5/16-12 UN |
| d3 | 120 | 120 |
| h1 | 110 | 162 |
| h3 | 18 | 18 |
| h4 | 60 | 90 |
| b1 | 44 | 44 |
| SW | 41 | 41 |
| Weight | 0.40 kg | 0.65 kg |

| Type | BF 7 "M" | BF 72 "M" |
|--------|-----------|-----------|
| d1 | 116 | 116 |
| d2 | M30 x 1.5 | M30 x 1.5 |
| d3 | 120 | 120 |
| h1 | 110 | 162 |
| h3 | 23.5 | 23.5 |
| h4 | 60 | 90 |
| b1 | 44 | 44 |
| SW | 36 | 36 |
| Weight | 0.40 kg | 0.65 kg |

BF 5

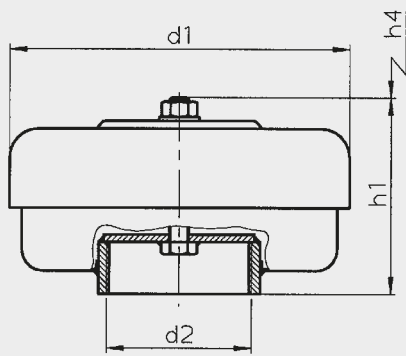

BF 52

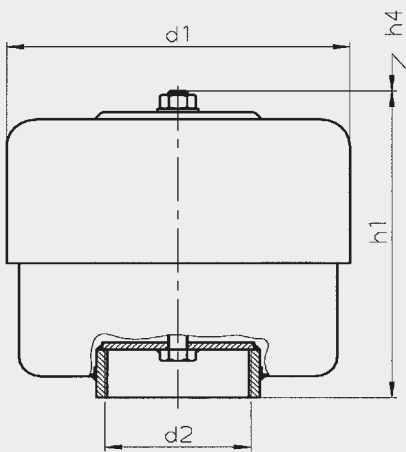

| Type | BF 5 "G"... | BF 52 "G"... |
|--------|-------------|--------------|
| d1 | 177 | 177 |
| d2 | G 2½ | G 2½ |
| h1 | 107 | 173 |
| h4 | 90 | 90 |
| Weight | 2.00 kg | 2.60 kg |

| Type | BF 5 "N"... | BF 52 "N"... |
|--------|-------------|--------------|
| d1 | 177 | 177 |
| d2 | NPT 2½ | NPT 2½ |
| h1 | 107 | 173 |
| h4 | 90 | 90 |
| Weight | 2.00 kg | 2.60 kg |

BF 8

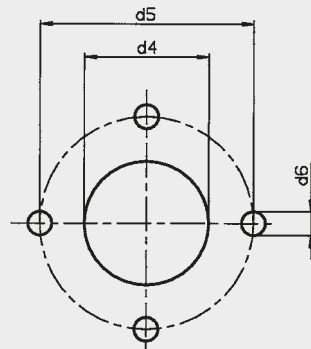
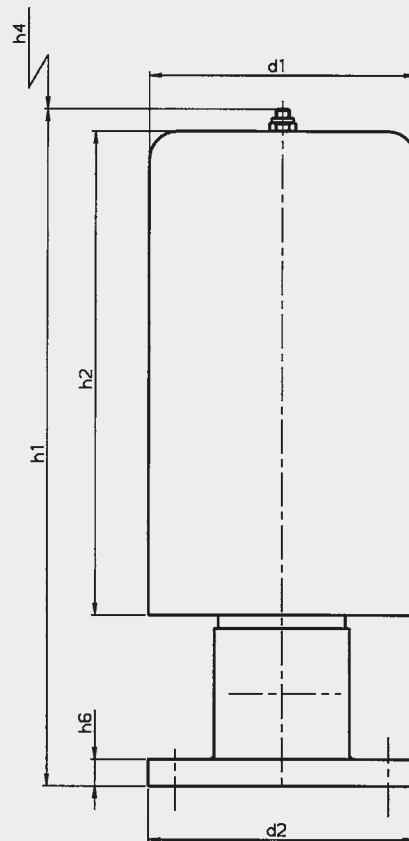

Interface

| Type | BF 8... |
|--------|---------|
| d1 | 200 |
| d2 | 200 |
| d4 | 93 |
| d5 | 160 |
| d6 | 18 |
| h1 | 510 |
| h2 | 365 |
| h4 | 400 |
| h6 | 20 |
| Weight | 12.4 kg |

BF 9

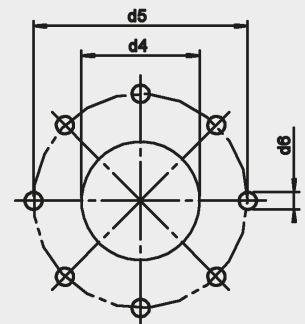
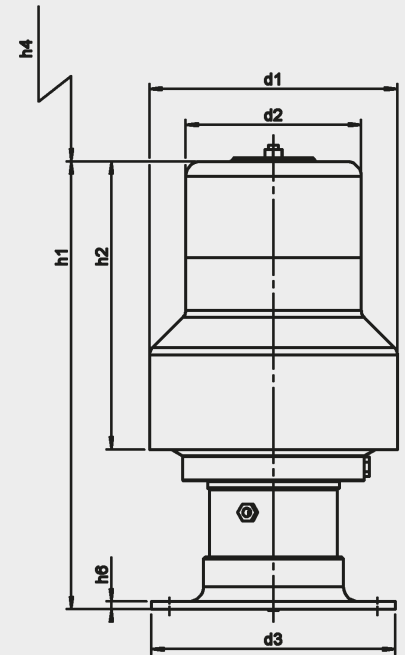

Interface

| Type | BF 9... |
|--------|---------|
| d1 | 250 |
| d2 | 177 |
| d3 | 246 |
| d4 | 116 |
| d5 | 210 |
| d6 | 17 |
| h1 | 455 |
| h2 | 290 |
| h4 | 330 |
| h6 | 8 |
| Weight | 6.2 kg |

NOTE

The information in this brochure relates to the operating conditions and applications described.

For applications or operating conditions not described, please contact the relevant technical department.

Subject to technical modifications.

HYDAC Filtrertechnik GmbH

Industriegebiet
D-66280 Sulzbach/Saar

Tel.: 0 68 97 / 509-01

Fax: 0 68 97 / 509-300

Internet: www.hydac.com

E-Mail: filter@hydac.com